

ACTUATOR SERIES ARA600 PROPORTIONAL



Proportional

ESBE Actuator Series ARA600 for operating ESBE mixing valves DN 15-50. The actuators have an operating range of 90° and can easily be manually operated. Patented + Registered design.

OPERATION

The ESBE series ARA600 is a compact actuator designed for operating rotary mixing valves DN 15-50. The actuators ARA6X9 are controlled by proportional signal, and are recommended for mixing applications. The actuator has an operating range of 90° and the valve can easily be manually operated by the pull-and-turn knob on the front of the actuator.

In addition to the proportional signal control, actuators series ARA639 can also be used for 3- and 2-point signal control.

VERSIONS

The actuators ARA6X9 are available for 24 V AC/DC, 50/60 Hz power supply. An auxiliary switch, which can be set in any position, is available as an optional kit to be ordered separately. The auxiliary switch is easily set by a unique solution, by just lifting off the turning knob the switch cam is accessible, no tools or disassembly required.

The ARA659 can be set to running times of 45 and 120 seconds and is supplied with a 1.5 m cable attached.

The ARA639 can be set to running times of 15, 30, 60 and 120 seconds. The ARA639 also have the additional features of proportional analogue output signal for monitoring devices etc, optional advanced noise reduction of the input signal and positioning memory for fast startup after power failure.

SUITABLE MIXING VALVES

Thanks to the special interface between the actuator series ARA600 and the ESBE valve series VRG and VRB, the unit as a whole has a unique stability and precision when regulating. The actuator series ARA600 is also easily mounted on the ESBE valve series MG, G, F, BIV, T, TM, H and HG.

- Series VRG100
- Series MG
- Series VRG200
- Series G
- Series VRG300
- Series F ≤ DN50
- Series VRH100
- Series BIV
- Series VRB100
- Series T and TM
- Series H and HG

ADAPTOR KITS

The actuator is supplied complete with an adaptor kit for easily fitting onto an ESBE rotary mixing valve. Adaptor kits can also be ordered separately.

Art. No.

16000400 ___ ESBE valve series G, MG, F, BIV, T, TM, H, HG

16000500 (= supplied with actuator)

___ ESBE valve series VRG, VRB, G, MG, F, BIV, T, TM, H, HG

TECHNICAL DATA

Ambient temperature: _____ max. +55°C

_____ min. -5°C

Power supply: _____ 24 ± 10% V AC/DC, 50/60 Hz

Enclosure rating: _____ IP41

Protection class: _____ II

Torque: _____ See table

Power consumption - Operation, AC: _____ 5 W

DC: _____ 2.5 W

Power consumption - Dimensioning, AC: _____ ARA639, 11 VA

_____ ARA659, 8 VA

DC: _____ ARA639, 6 VA

_____ ARA659, 4 VA

Rating auxiliary switch: _____ 6(3) A 250 V AC

Weight: _____ 0.4 kg

WIRING

The actuator should be preceded by a multi-pole contact breaker in the fixed installation.

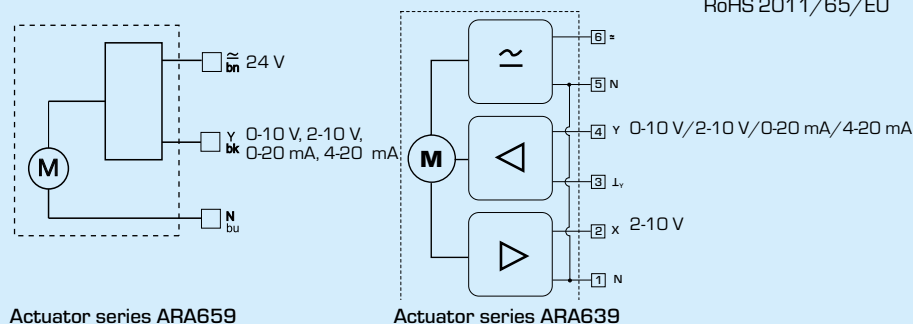

CE LVD 2014/35/EU
EMC 2014/30/EU
RoHS 2011/65/EU

ACTUATOR

SERIES ARA600 PROPORTIONAL

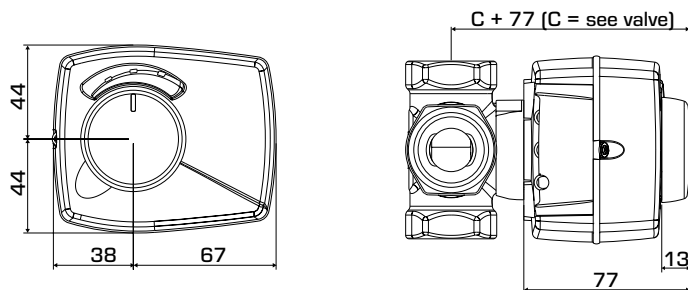

Installation dimensions for Actuator Series ARA600 with ESBE VRG100, VRG200, VRG300 and VRB100 mixing valves

SERIES ARA600, PROPORTIONAL 24 V AC/DC

Art. No.	Reference	Voltage [V]	Running time 90° [s]	Control signal	Torque [Nm]	Note
12520100	ARA639	24	15/30/60/120	0..10 V, 2..10 V, 0..20mA, 4..20mA	6	
12520200	ARA659	24	45/120	0..10 V, 2..10 V, 0..20mA, 4..20mA	6	

Adaptor kits for other mixing valves are available as follows:

Art. No.
 16000600 _____ Meibes
 16000700 _____ Watts
 16000800 _____ Honeywell Corona
 16000900 _____ Lovato
 16001000 _____ PAW

OPTION

Art. No.
 16200700 _____ Auxiliary switch kit
 16200800 _____ Cable hatch